

QUICK RELEASING/REVERSE FLOW PREVENTION VALVE "SENTINEL"

APOLLO COUPLING SERIES



Gas welding/cutting operation a must for the safety & efficiency.

Koike has always been after higher safety and easier handling in developing its gas welding/cutting equipment. This Apollo Coupling is one of the outstanding results of Koike's efforts. The Apollo Coupling is fitted to the outlet pipe, connecting hose, and the welding/cutting machine and outfit, removing

possible risks accompanying the gas welding/cutting operation and making preparation and maintenance of the welding/cutting machines easy.

Further, each type is specially designed for oxygen or fuel gas so as to prevent mistakes.

Snap Fitting Type



KOIKE SANSO KOGYO CO.,LTD.

APOLLO COUPLINGS

"SENTINEL"

FEATURES & SINGLE CONNECTIONS

GOOD REVERSE-FLOW PREVENTION

The reverse-flow prevention valve stops the gases mixing so that the cause of possible explosion is eliminated completely: when flashback occurs owing to welding/cutting machine trouble, it shuts off flashback pressure and stops the gases mixing.

QUICK-FIT & RELEASE

Spring-load locking method is used, so gas flows immediately after it is fitted. Removal is also single-action.

SPECIFICATIONS

- Max. working pressure For oxygen: 10kg/cm²
For fuel gas: 2kg/cm²
- Check valve working pressure 0.015kg/cm²
(0.2 lb/in²)
- Endurance test (by UL) 30,000

PRODUCTS FOR EUROPE Other combinations are available. Please select among "Single Parts" and specify.

● FOR OXYGEN

| | | Model (Stock No.) | Socket (Stock No.) | Plug (Stock No.) | Thread size (R.H.T.) | Hose nipple outer dia |
|--------------------------|--|--------------------|--------------------|-------------------|----------------------|-----------------------|
| Regulator to hose | | ZGSP-1 (323-2310) | GS-1 (323-2311) | ZAP-1 (323-2312) | DINR 1/4 - 19 | Maxφ8.2MM |
| | | ZGSP-1 (323-2320) | GS-1 (323-2321) | ZAP-1 (323-2322) | DINR 3/8 - 19 | Maxφ9.2MM |
| Hose to hose | | ZASP-1 (323-2370) | AS-1 (323-2341) | ZAP-1 (323-2312) | — | Maxφ8.2MM |
| | | ZASP-1 (323-2380) | AS-1 (323-2351) | ZAP-1 (323-2322) | — | Maxφ9.2MM |
| Hose to machine or torch | | ZOSP-1 (323-2340) | AS-1 (323-2341) | ZOP-1 (323-2342) | DINR 1/4 - 19 | Maxφ8.2MM |
| | | ZOSP-1 (323-2350) | AS-1 (323-2351) | ZOP-1 (323-2352) | DINR 3/8 - 19 | Maxφ9.2MM |
| | | ZOSP-1A (323-2315) | AS-1 (323-2341) | ZOP-1A (323-2372) | DINR 1/4 - 19 | Maxφ8.2MM |
| | | ZOSP-1A (323-2345) | AS-1 (323-2351) | ZOP-1A (323-2472) | DINR 3/8 - 19 | Maxφ9.2MM |
| | | ZOSP-1L (323-2415) | AS-1L (323-2371) | ZOP-1 (323-2342) | DINR 1/4 - 19 | Maxφ8.2MM |
| | | ZOSP-1L (323-2435) | AS-1L (323-2373) | ZOP-1 (323-2352) | DINR 3/8 - 19 | Maxφ9.2MM |

● FOR FUEL GAS

| | | Model (Stock No.) | Socket (Stock No.) | Plug (Stock No.) | Thread size (L.H.T.) | Hose nipple outer dia |
|--------------------------|--|--------------------|--------------------|-------------------|----------------------|-----------------------|
| Regulator to hose | | ZGSP-2 (323-2330) | GS-2 (323-2331) | ZAP-2 (323-2332) | DINR 3/8 - 19 | Maxφ11MM |
| | | ZGSP-2 (323-2335) | GS-2 (323-2331) | ZAP-2 (323-2334) | DINR 3/8 - 19 | Maxφ8.2MM |
| Hose to hose | | ZASP-2 (323-2390) | AS-2 (323-2361) | ZAP-2 (323-2332) | — | Maxφ11MM |
| | | ZASP-2 (323-2395) | AS-2 (323-2363) | ZAP-2 (323-2334) | — | Maxφ8.2MM |
| Hose to machine or torch | | ZOSP-2 (323-2360) | AS-2 (323-2361) | ZOP-2 (323-2362) | DINR 3/8 - 19 | Maxφ11MM |
| | | ZOSP-2 (323-2365) | AS-2 (323-2363) | ZOP-2 (323-2362) | DINR 3/8 - 19 | Maxφ8.2MM |
| | | ZOSP-2A (323-2325) | AS-2 (323-2361) | ZOP-2A (323-2392) | DINR 3/8 - 19 | Maxφ11MM |
| | | ZOSP-2A (323-2385) | AS-2 (323-2363) | ZOP-2A (323-2392) | DINR 3/8 - 19 | Maxφ8.2MM |
| | | ZOSP-2L (323-2425) | AS-2L (323-2391) | ZOP-2 (323-2362) | DINR 3/8 - 19 | Maxφ11MM |
| | | ZOSP-2L (323-2445) | AS-2L (323-2393) | ZOP-2 (323-2362) | DINR 3/8 - 19 | Maxφ8.2MM |

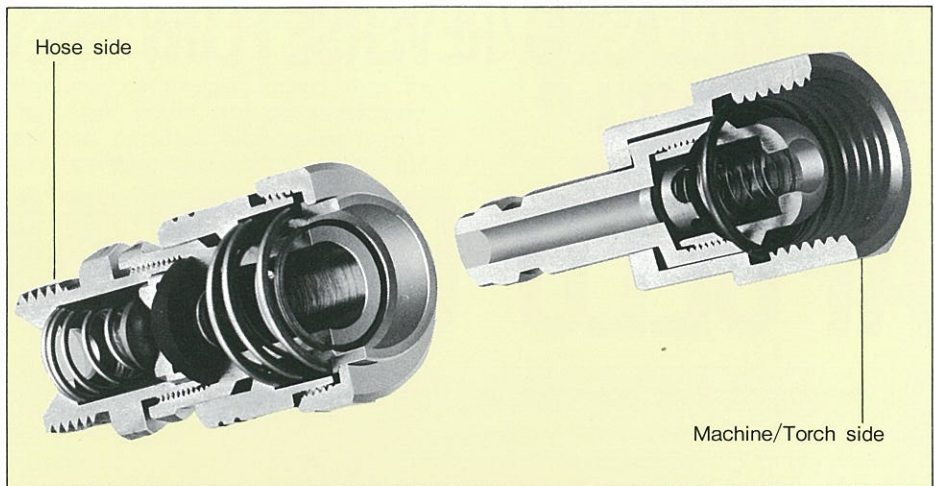

HANDLING PRECAUTIONS

- After installation, do not forget to check the connection for leaks.
- Testing should be carried out periodically
- Never lubricate fittings! keep grease and oil away from connections.
- In case of flashback or backfire, this fitting should be replaced with a new one.

Speed up your jobs with this quick fit and release valve.

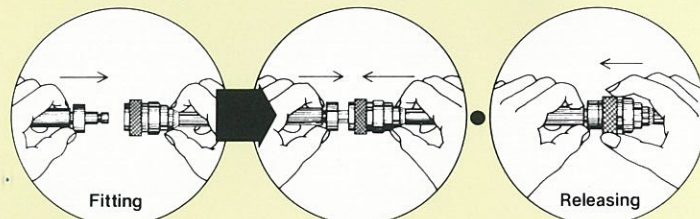

- Hold the plug and socket by sections other than the sleeve.
- Press together until a click indicates connection is complete.
- Press the sleeve towards the plug side.

APOLLO COUPLINGS

"SENTINEL"

SINGLE PARTS

LOCK TYPE

This type, specially designed for the utmost safety and durability, employs a locking method. It is suitable for the jobs which require hard work.

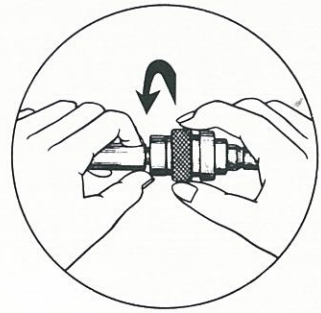

SURVEY OF ALL THE KOIKE PRODUCTS

FOR OXYGEN

SOCKET

FOR REGULATOR

GS-1



| ★ (Thread size) | Stock No. |
|---------------------------|------------|
| US 9/16 - 18 UNF (R.H.T.) | 323 - 2021 |
| DINR 1/4 - 19 (R.H.T.) | 323 - 2311 |
| DINR 3/8 - 19 (R.H.T.) | 323 - 2321 |
| BSPF 1/4 - 19 (R.H.T.) | 323 - 2521 |
| BSPF 3/8 - 19 (R.H.T.) | 323 - 2621 |
| 5/8 - 18 UNF (R.H.T.) | 323 - 2721 |
| JIS M16 x 1.5 (R.H.T.) | 323 - 2821 |

FOR CONNECTING HOSE

AS-1



| ★ (Hose nipple outer dia) | Stock No. |
|---------------------------|------------|
| Maxφ6mm | 323 - 2963 |
| Maxφ7mm | 323 - 2967 |
| Maxφ8.2mm | 323 - 2341 |
| Maxφ9.2mm | 323 - 2351 |
| Maxφ11mm | 323 - 2961 |

FOR CONNECTING HOSE

ZAP-1

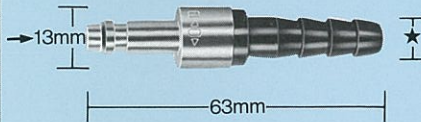

| ★ (Hose nipple outer dia) | Stock No. |
|---------------------------|------------|
| Maxφ6mm | 323 - 2924 |
| Maxφ7mm | 323 - 2926 |
| Maxφ8.2mm | 323 - 2312 |
| Maxφ9.2mm | 323 - 2322 |
| Maxφ11mm | 323 - 2922 |

ZAP-1

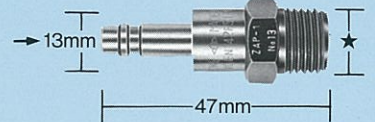

| ★ (Thread size) | Stock No. |
|---------------------------|------------|
| US 9/16 - 18 UNF (R.H.T.) | 323 - 2022 |
| BSPF 1/4 - 19 (R.H.T.) | 323 - 2522 |
| BSPF 3/8 - 19 (R.H.T.) | 323 - 2622 |
| 5/8 - 18 UNF (R.H.T.) | 323 - 2722 |
| JIS M16 x 1.5 (R.H.T.) | 323 - 2822 |

FOR FUEL GAS

SOCKET

FOR REGULATOR

GS-2

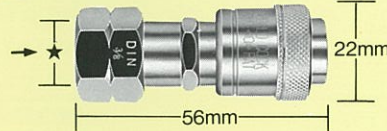

| ★ (Thread size) | Stock No. |
|---------------------------|------------|
| US 9/16 - 18 UNF (L.H.T.) | 323 - 2041 |
| DINR 1/4 - 19 (L.H.T.) | 323 - 2333 |
| DINR 3/8 - 19 (L.H.T.) | 323 - 2331 |
| BSPF 1/4 - 19 (L.H.T.) | 323 - 2541 |
| BSPF 3/8 - 19 (L.H.T.) | 323 - 2641 |
| 5/8 - 18 UNF (L.H.T.) | 323 - 2741 |
| JIS M16 x 1.5 (L.H.T.) | 323 - 2841 |

FOR CONNECTING HOSE

AS-2

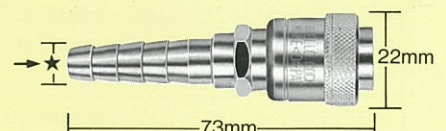

| ★ (Hose nipple outer dia) | Stock No. |
|---------------------------|------------|
| Maxφ6mm | 323 - 2983 |
| Maxφ7mm | 323 - 2987 |
| Maxφ8.2mm | 323 - 2363 |
| Maxφ9.2mm | 323 - 2981 |
| Maxφ11mm | 323 - 2361 |

FOR CONNECTING HOSE

ZAP-2

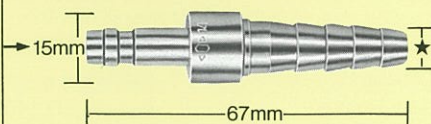

| ★ (Hose nipple outer dia) | Stock No. |
|---------------------------|------------|
| Maxφ6mm | 323 - 2944 |
| Maxφ7mm | 323 - 2946 |
| Maxφ8.2mm | 323 - 2334 |
| Maxφ9.2mm | 323 - 2942 |
| Maxφ11mm | 323 - 2332 |



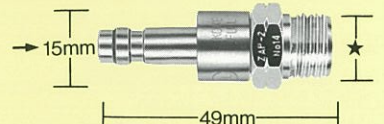

ZAP-2



| ★ (Thread size) | Stock No. |
|---------------------------|------------|
| US 9/16 - 18 UNF (L.H.T.) | 323 - 2042 |
| BSPF 1/4 - 19 (L.H.T.) | 323 - 2542 |
| BSPF 3/8 - 19 (L.H.T.) | 323 - 2642 |
| 5/8 - 18 UNF (L.H.T.) | 323 - 2742 |
| JIS M16 x 1.5 (L.H.T.) | 323 - 2842 |

PLUG

Special specification parts are available for connection without check valve.

| | Model (stock No.) | Thread size | Hose nipple outer dia | Gas in use |
|---|-------------------|------------------|-----------------------|------------|
|  | AP-1 (323-2414) | — | Maxφ8.2MM | oxygen |
| | AP-1 (323-2424) | — | Maxφ9.2MM | oxygen |
|  | AP-2 (323-2434) | — | Maxφ11MM | fuel gas |
| | AP-2 (323-2474) | — | Maxφ8.2MM | fuel gas |
|  | OP-1 (323-2444) | DINR1/4-19 (RHT) | — | oxygen |
| | OP-1 (323-2454) | DINR3/8-19 (RHT) | — | oxygen |
|  | OP-2 (323-2464) | DINR3/8-19 (LHT) | — | fuel gas |

-1



| ★ (Thread size) | Stock No. |
|-------------------------|-----------|
| US 9/16-18 UNF (R.H.T.) | 323-2061 |
| BSPF 1/4-19 (R.H.T.) | 323-2561 |
| BSPF 3/8-19 (R.H.T.) | 323-2661 |
| 5/8-18 UNF (R.H.T.) | 323-2761 |
| JIS M16 x 1.5 (R.H.T.) | 323-2861 |

AS-1L(Lock type)



| ★ (Hose nipple outer dia) | Stock No. |
|---------------------------|-----------|
| Maxφ6mm | 323-2973 |
| Maxφ7mm | 323-2977 |
| Maxφ8.2mm | 323-2371 |
| Maxφ9.2mm | 323-2373 |
| Maxφ11mm | 323-2971 |

AS-1L(Lock type)



| ★ (Thread size) | Stock No. |
|-------------------------|-----------|
| US 9/16-18 UNF (R.H.T.) | 323-2161 |
| BSPF 1/4-19 (R.H.T.) | 323-2571 |
| BSPF 3/8-19 (R.H.T.) | 323-2671 |
| 5/8-18 UNF (R.H.T.) | 323-2771 |
| JIS M16 x 1.5 (R.H.T.) | 323-2871 |

OR WELDING/CUTTING MACHINE
OP-1



| ★ (Thread size) | Stock No. |
|-------------------------|-----------|
| US 9/16-18 UNF (R.H.T.) | 323-2062 |
| DINR 1/4-19 (R.H.T.) | 323-2342 |
| DINR 3/8-19 (R.H.T.) | 323-2352 |
| BSPF 1/4-19 (R.H.T.) | 323-2562 |
| BSPF 3/8-19 (R.H.T.) | 323-2662 |
| 5/8-18 UNF (R.H.T.) | 323-2762 |
| JIS M16 x 1.5 (R.H.T.) | 323-2862 |

ZOP-1A



| ★ (Thread size) | Stock No. |
|-------------------------|-----------|
| US 9/16-18 UNF (R.H.T.) | 323-2272 |
| DINR 1/4-19 (R.H.T.) | 323-2372 |
| DINR 3/8-19 (R.H.T.) | 323-2472 |
| BSPF 1/4-19 (R.H.T.) | 323-2572 |
| BSPF 3/8-19 (R.H.T.) | 323-2672 |
| 5/8-18 UNF (R.H.T.) | 323-2772 |
| JIS M16 x 1.5 (R.H.T.) | 323-2872 |

AS-2L(Lock type)



| ★ (Thread size) | Stock No. |
|-------------------------|-----------|
| US 9/16-18 UNF (L.H.T.) | 323-2081 |
| BSPF 1/4-19 (L.H.T.) | 323-2581 |
| BSPF 3/8-19 (L.H.T.) | 323-2681 |
| 5/8-18 UNF (L.H.T.) | 323-2781 |
| JIS M16 x 1.5 (L.H.T.) | 323-2881 |

AS-2L(Lock type)

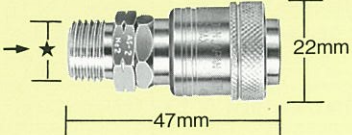

| ★ (Hose nipple outer dia) | Stock No. |
|---------------------------|-----------|
| Maxφ6mm | 323-2993 |
| Maxφ7mm | 323-2997 |
| Maxφ8.2mm | 323-2393 |
| Maxφ9.2mm | 323-2991 |
| Maxφ11mm | 323-2391 |

AS-2L(Lock type)



| ★ (Thread size) | Stock No. |
|-------------------------|-----------|
| US 9/16-18 UNF (L.H.T.) | 323-2181 |
| BSPF 1/4-19 (L.H.T.) | 323-2591 |
| BSPF 3/8-19 (L.H.T.) | 323-2691 |
| 5/8-18 UNF (L.H.T.) | 323-2791 |
| JIS M16 x 1.5 (L.H.T.) | 323-2891 |

OR WELDING/CUTTING MACHINE
OP-2

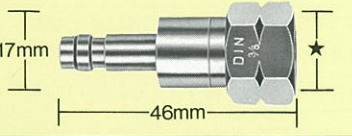

| ★ (Thread size) | Stock No. |
|-------------------------|-----------|
| US 9/16-18 UNF (L.H.T.) | 323-2082 |
| DINR 1/4-19 (L.H.T.) | 323-2364 |
| DINR 3/8-19 (L.H.T.) | 323-2362 |
| BSPF 1/4-19 (L.H.T.) | 323-2582 |
| BSPF 3/8-19 (L.H.T.) | 323-2682 |
| 5/8-18 UNF (L.H.T.) | 323-2782 |
| JIS M16 x 1.5 (L.H.T.) | 323-2882 |

ZOP-2A



| ★ (Thread size) | Stock No. |
|-------------------------|-----------|
| US 9/16-18 UNF (L.H.T.) | 323-2292 |
| DINR 1/4-19 (L.H.T.) | 323-2492 |
| DINR 3/8-19 (L.H.T.) | 323-2392 |
| BSPF 1/4-19 (L.H.T.) | 323-2592 |
| BSPF 3/8-19 (L.H.T.) | 323-2692 |
| 5/8-18 UNF (L.H.T.) | 323-2792 |
| JIS M16 x 1.5 (L.H.T.) | 323-2892 |

AS-2L(Lock type)



| ★ (Thread size) | Stock No. |
|-------------------------|-----------|
| US 9/16-18 UNF (L.H.T.) | 323-2081 |
| BSPF 1/4-19 (L.H.T.) | 323-2581 |
| BSPF 3/8-19 (L.H.T.) | 323-2681 |
| 5/8-18 UNF (L.H.T.) | 323-2781 |
| JIS M16 x 1.5 (L.H.T.) | 323-2881 |

APOLLO COUPLING SET

"SENTINEL"

SAFETY-Z

This UL approved SAFETY-Z COUPLING SET, the first on the market, reduces possible risks accompanying gas welding/cutting operations. These couplings assure line connections; easy click-in click-out design and good reverse-flow prevention.

A coupling sets are available; one set for regulator-hose and hose-machine, other sets for regulator-hose, hose-hose, hose-machine. Also, each is specifically designed for oxygen or fuel gas, removing possibility of error as an incorrect connection will not allow gas flow.

Reliable safe gas cutting operations and reduced preparation operations are achieved with the SAFETY-Z COUPLING SET.



SAFETY-Z COUPLING ARE USED IN THE FOLLOWING PLACES

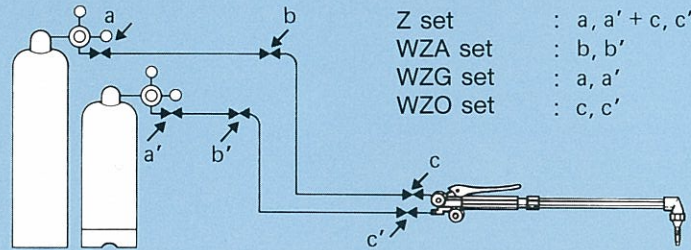

PRODUCTS FOR EUROPE

Other combinations are available. Please select among "Single Parts" and specify.

| Name (Stock No.) | | Model (Stock No.) | Socket (Stock No.) | Plug (Stock No.) | Gas in use | Thread size | Hose nipple outer dia |
|----------------------------|-------------------|-------------------|--------------------|------------------|------------|--------------------|-----------------------|
| Z Set (WZG+WZO) (323-2300) | Regulator to hose | ZGSP-1(323-2310) | GS-1(323-2311) | ZAP-1(323-2312) | Oxygen | DINR1/4-19(R.H.T.) | Maxφ8.2MM |
| | | ZGSP-2(323-2330) | GS-2(323-2331) | ZAP-2(323-2332) | Fuel gas | DINR3/8-19(L.H.T.) | Maxφ11MM |
| | Hose to machine | ZOSP-1(323-2340) | AS-1(323-2341) | ZOP-1(323-2342) | Oxygen | DINR1/4-19(R.H.T.) | Maxφ8.2MM |
| | | ZOSP-2(323-2360) | AS-2(323-2361) | ZOP-2(323-2362) | Fuel gas | DINR3/8-19(L.H.T.) | Maxφ11MM |
| WZA Set (323-2430) | Hose to hose | ZASP-1(323-2370) | AS-1(323-2341) | ZAP-1(323-2312) | Oxygen | — | Maxφ8.2MM |
| | | ZASP-2(323-2390) | AS-2(323-2361) | ZAP-2(323-2332) | Fuel gas | — | Maxφ11MM |
| WZG Set (323-2410) | Regulator to hose | ZGSP-1(323-2310) | GS-1(323-2311) | ZAP-1(323-2312) | Oxygen | DINR1/4-19(R.H.T.) | Maxφ8.2MM |
| | | ZGSP-2(323-2330) | GS-2(323-2331) | ZAP-2(323-2332) | Fuel gas | DINR3/8-19(L.H.T.) | Maxφ11MM |
| WZO Set (323-2450) | Hose to machine | ZOSP-1(323-2340) | AS-1(323-2341) | ZOP-1(323-2342) | Oxygen | DINR1/4-19(R.H.T.) | Maxφ8.2MM |
| | | ZOSP-2(323-2360) | AS-2(323-2361) | ZOP-2(323-2362) | Fuel gas | DINR3/8-19(L.H.T.) | Maxφ11MM |

| Name (Stock No.) | | Model (Stock No.) | Socket (Stock No.) | Plug (Stock No.) | Gas in use | Thread size | Hose nipple outer dia |
|----------------------------|-------------------|-------------------|--------------------|------------------|------------|--------------------|-----------------------|
| Z Set (WZG+WZO) (323-2301) | Regulator to hose | ZGSP-1(323-2320) | GS-1(323-2321) | ZAP-1(323-2322) | Oxygen | DINR3/8-19(R.H.T.) | Maxφ9.2MM |
| | | ZGSP-2(323-2330) | GS-2(323-2331) | ZAP-2(323-2332) | Fuel gas | DINR3/8-19(L.H.T.) | Maxφ11MM |
| | Hose to machine | ZOSP-1(323-2350) | AS-1(323-2351) | ZOP-1(323-2352) | Oxygen | DINR3/8-19(R.H.T.) | Maxφ9.2MM |
| | | ZOSP-2(323-2360) | AS-2(323-2361) | ZOP-2(323-2362) | Fuel gas | DINR3/8-19(L.H.T.) | Maxφ11MM |
| WZA Set (323-2440) | Hose to hose | ZASP-1(323-2380) | AS-1(323-2351) | ZAP-1(323-2322) | Oxygen | — | Maxφ9.2MM |
| | | ZASP-2(323-2390) | AS-2(323-2361) | ZAP-2(323-2332) | Fuel gas | — | Maxφ11MM |
| WZG Set (323-2420) | Regulator to hose | ZGSP-1(323-2320) | GS-1(323-2321) | ZAP-1(323-2322) | Oxygen | DINR3/8-19(R.H.T.) | Maxφ9.2MM |
| | | ZGSP-2(323-2330) | GS-2(323-2331) | ZAP-2(323-2332) | Fuel gas | DINR3/8-19(L.H.T.) | Maxφ11MM |
| WZO Set (323-2460) | Hose to machine | ZOSP-1(323-2350) | AS-1(323-2351) | ZOP-1(323-2352) | Oxygen | DINR3/8-19(R.H.T.) | Maxφ9.2MM |
| | | ZOSP-2(323-2360) | AS-2(323-2361) | ZOP-2(323-2362) | Fuel gas | DINR3/8-19(L.H.T.) | Maxφ11MM |